

TNI-System

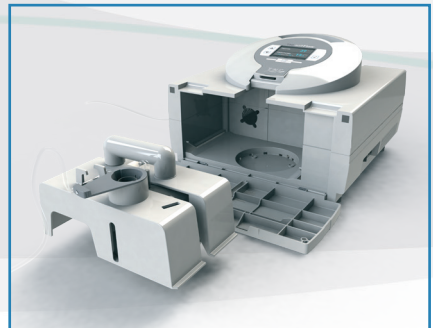

C

ONTENTS

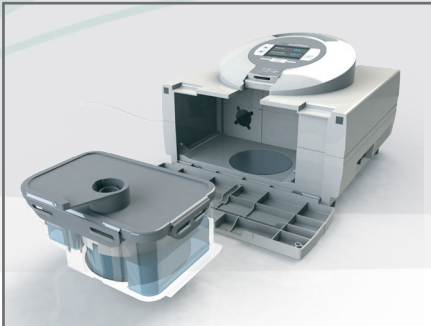
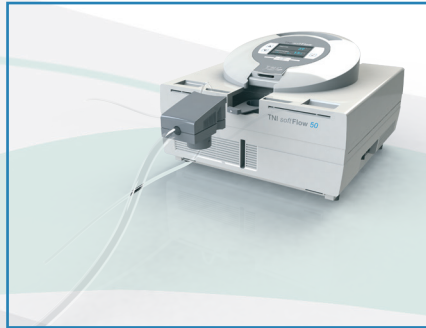

Improvement of Ventilation	4
Therapeutic Benefit	5
Statements according to the newest studies on TNI	6
TNI <i>soft Flow 50</i>	8
TNI <i>soft Flow junior</i>	9
TNI studies, posters and publications	10
How is nHF rated in clinical use internationally today?	16
Why choose TNI <i>soft Flow</i>	19



IMPROVING VENTILATION WITH

Therapy with |N|asal |I|nsufflation

The therapy with nasal insufflation (TNI[®]) was developed for both clinical intensive and inpatient care as well as for home care use. Patients show a high tolerance for this therapy and it is even suitable in cases where conventional respiratory masks are not tolerated very well.

TNI[®] (Therapy with Nasal Insufflation) has been known in clinical everyday life though it is still a new respiratory support method. It is a nasal high-flow ventilation method.

METHODS AND EFFICACY

In therapy with nasal insufflation, a constant, warm and humidified airstream is conducted into the patient's nose via a thin nasal cannula (applicator); if required, oxygen can be added to the stream. This generally leads to improved ventilation. Therapy with nasal insufflation shows a high tolerance with excellent success.

Plenty of evidence and clinical findings exist that prove that nasal therapy insufflation

- shows a clinical use
- can be safely applied on patients suffering from COPD and ILD
- supports non-sufficient respiration
- helps eliminate CO₂
- guarantees constant FiO₂ during therapy

- quickly reduces hyperinflation
- increases pressure in the entire respiratory tract, affecting inspiration and expiration
- decreases functional dead space
- significantly relieves the respiratory pump
- requires less oxygen while simultaneously improving SaO₂
- facilitates coughing up phlegm and causes a better mucociliary clearance conditioned by effective humidity management

The presented findings support therapy with nasal insufflation in particular as an alternative option to NIV therapy for further reducing mechanical respiratory support or for patients who do not tolerate a conventional respiratory mask.

The therapy is applied successfully in clinical intensive and inpatient care as well as in home care.

THERAPEUTIC BENEFIT

This type of therapy is suitable for patients who suffer from:

1. COPD (chronic obstructive pulmonary disease).
2. ILD (interstitial lung disease).
3. partial or global respiratory insufficiency in order to support breathing.
4. mild to moderate OSA (obstructive sleep apnea).

Therapy for nasal insufflation is a renowned method of therapy for respiratory support in premature babies and infants and is now available in home care areas with the devices from the TNI® product line.

Areas of therapy include the following syndrome in premature babies and infants:

1. IRDS (infant respiratory distress syndrome)
2. BPD (bronchopulmonary dysplasia)
3. bronchiolitis
4. dyspnea in newborns
5. postextubation
6. Down syndrome
7. sleep disordered breathing
8. midface hypoplasia in children
9. apnea-bradycardia-syndrome
10. FRC reduction (edema, "wet lung")
11. mild dyspnea in premature babies
12. malacic disorders in the respiratory tract
13. transitory tachypnea
14. mild atelectases

Only an **exact**, regulated **flowrate** (in l/min) consisting of air or a **air-O₂ mixture** ensures a **high quality therapy** without side-effects

for **clinical** and **home care** settings, **guarantees** a stable FiO₂ and confirms our **study results**:



STATEMENTS ACCORDING TO THE STUDIES ON TNI:

” NIV with TNI “

The application of therapy with nasal insufflation (TNI®) has no side effects!

The application of TNI® shows a clinical benefit in COPD and ILD!

The application of TNI® for patients with COPD or ILD is safe and leads to no negative effects regarding pulmonary function parameters!

The application of TNI® is ideally suited for children and adults who suffer from obstructive sleep apnea!

We have been actively conducting research for years in this field which has helped us to develop our TNI systems.

What is more, the applied correct flowrate consisting of air or air-O₂ mixtures determine the magnitude of therapy; the supplied air remains in the same quality and with extended parameters as is the case in our current products.

With the new **TNI softFlow** systems, TNI® medical AG provides new medical products which correspond to the newest discoveries in therapy with nasal insufflation in all ways.

FROM THE CLINIC TO HOME CARE

- with the **TNI softFlow** system you will be able to fulfill all clinical requirements
- with the **TNI softFlow** system you will be able to fulfill all clinical requirements identically and safely in succeeding home care therapy as well

Two different models are available for the **TNI softFlow** systems and convince through the following benefits:

The exact flowrate can be individually adjusted for each patient!

A stable FiO₂ is guaranteed and displayed at any point of the therapy!

A well-engineered humidity management is obligatory for high and low flowrates!

Perfected hygiene concept

LTOT during power outages

Heating to the tip of the nose

Professional usage in the clinical and home care settings

Integrated into one housing



TNI soft Flow 50

- flowrate 10 to 50 l/min
- adjustable in 0.5 l/min steps
- tolerances $\pm 2\%$
- oxygen admixture of 0 to 20 l/min possible - l/min indicator in the display
- FiO₂ indicator integrated in the display
- Humidity, dew point of 30° to 37° C, adjustable in 1° C-steps
- The system can be used in various ways in the clinic with greatest hygienic safety or at home with easy handling.
- Individual variety of applicators
- automatic identification of applicator type
- condensate-free gas-air flow management for pleasant therapy

Professional use in clinical settings

- comes with auto fill humidification chamber
- comes with an MRE filter

Professional use in home care settings

- comes with 600 ml water tank
- for use with tap water or demineralised water
- auto fill humidification chamber (optional)



TNI *soft Flow junior*

- flowrate 2 to 15 l/min
- adjustable in 0.5 l/min steps
- tolerances $\pm 2\%$
- oxygen admixture of 0 to 12 l/min possible - l/min indicator in the display
- FiO₂ indicator integrated in the display
- Humidity, dew point of 30° to 37° C, adjustable in 1° C-steps
- The system can be used in various ways in the clinic with greatest hygienic safety or at home with easy handling.
- Individual variety of applicators
- automatic identification of applicator type
- condensate-free gas-air flow management for pleasant therapy

Professional use in clinical settings

- comes with auto fill humidification chamber
- comes with an MRE filter

Professional use in home care settings

- comes with 600 ml water tank
- for use with tap water or demineralised water
- auto fill humidification chamber (optional)





Since 2008, TNI® medical AG has been doing systematic research in the field of nasal insufflation due to respiratory insufficiency.

We have been active in the market for obstructive sleep apnea (OSA) since 2006. We started conducting research in this field at an early stage; a list of publications will follow below. Effects received from TNI®20 oxy, which lead to reduced respiratory drive:

- TNI®20 oxy increases the mean airway pressure (e.g. trachea)
- TNI®20 oxy increases airway pressure amplitude (increases tidal volume)
- TNI®20 oxy reduces respiratory rate (relief reaction)
- TNI®20 oxy reduces respiratory minute volume (efficiency increase)
- TNI®20 oxy enables a constant through flow of gas in the upper airways, washing out residing CO₂ and CO₂ inhaled with the next breath. Each breath therefore reduces more and more CO₂. Since the respiratory drive is dependent of CO₂, a reduction in CO₂ requires less respiratory drive, thus effecting a relieving of the respiratory muscles.

All in all, the impacts mentioned above result in increasing respiratory efficiency. The increase in efficiency (in terms of facilitated removal of CO₂) reduces necessary breathing and through this respiratory drive. The slight increase in airway pressure which increases tidal volume as well as the reduction observed in respiratory rate and respiratory minute volume are a sign of respiratory efficiency which contribute to improving the condition of the respiratory muscles.

STATEMENTS ON COPD AND ILD

2010

THERAPY WITH TNI® IS FREE FROM SIDE-EFFECTS

STIT-1: Evaluation of safety and efficacy of shorttime TNI® treatment in patients with COPD –First interim analysis.

Pneumology Service, Department of General Internal Medicine, Medical University of Innsbruck

H. Vogelsinger, M. Halank, S. Braun, S. Ott, S. Desole, T.Geiser, C.M. Kaehler

2010

PRESSURES IN THE PHARYNX CAN BE MEASURED WITH TNI® 20 OXY, 2-7 MBAR

Influence of transnasal insufflation (TNI) on airway pressure amplitude and mean respiratory pressure in comparison to spontaneous breathing and CPAP in patients with healthy lungs)

University of Leipzig, Pneumological Department, Department of Internal Medicine, Neurology and Dermatology

Bräunlich, J.; Beyer, D.; Hammerschmidt, S.; Seyfarth, H.-J.; Wirtz, H.

2010

DIFFERENTIATED FINDINGS IN THE SYNDROMES CHRONIC OBSTRUCTIVE PULMONARY DISEASE AND IDIOPATHIC PULMONARY FIBROSIS. A DECREASE IN $paCO_2$ CAN BE ASSUMED

Effects of high-flow transnasal insufflation compared with CPAP and spontaneous breathing on pressure amplitude and mean pressure in patients with IPF and COPD

Department of Respiratory Medicine, University of Leipzig, Leipzig

Bräunlich, J.; Mai, D., Beyer, D.; Hammerschmidt, S.; Seyfarth, H.-J.; Wirtz, H.

2012

RESIDUAL VOLUME COULD BE REDUCED SIGNIFICANTLY IN 18 OUT OF 40 PATIENTS IN A STUDY GROUP

Security and efficiency in short-term "high flow" insufflation in patients with severe COPD, evaluated based on pulmonary function parameters.

STIT-1: a prospective multi-center study initiated by an investigator.

Pneumology, Department of General Internal Medicine, Medical University of Innsbruck, Clinic and Policlinic for Pneumology, University Hospital of Bern, Inselspital Pneumologie, Medical Clinic and Policlinic I, University Hospital Carl Gustav Carus Dresden

H. Vogelsinger, J. Cleven, S. Ott, T. Geiser, S. Braun, M. Halank, C.M. Kaehler



2012

TNI® 20 OXY GUARANTEES A STEADY FIO₂ FLOW DURING THERAPY

Effect of transnasal "high-flow oxygen insufflation" on patients with severe COPD

*Pneumology, Department of General Internal Medicine, Medical University of Innsbruck
J.Cleven, H. Vogelsinger, S. Ott, T.Geiser, S. Braun, M. Halank, C.M. Kaehler*

2012

DIFFERENCES IN HEMODYNAMIC EFFECTS

Differences in Hemodynamic Effects between CPAP and nHF

*CSRT/GB;
Norman H Tiffin BSc, RRT, MSA and Stephen F. Connelly PhD*

2011

DECREASE IN RESPIRATORY RATE AND paCO₂

Comparison of nasal high flow therapy with single and dual prong application (TNIoxy) regarding respiration and gas exchange with stable hypercapnic respiratory failure COPD.)

HELIOS-Clinic Hagen-Ambrock, Witten/Herdecke University, Johns Hopkins University, Baltimore, U.S.A.

Georg Nilius¹, Ulrike Domanski¹, Christiane Brückner¹, Karl-Josef Franke¹, Karl-Heinz Rühle¹ und Hartmut Schneider².

CONCLUSION:

In the course of 45 minutes a day, a significant decrease in respiratory rate and paCO₂ can be achieved through the application of nasal high-flow therapy (TNI® 20 oxy) in patients suffering from COPD GOLD IV with a stable hypercapnia in comparison to LOT. The different effects of single-prong versus dual-prong application are suspected to be found in the decrease of dead space ventilation.

2011

TIDAL VOLUME IS INCREASED, RESPIRATORY RATE IS DECREASED, CO₂ IS WASHED OUT, THUS RELIEVING THE RESPIRATORY PUMP

Effects of a nasal high-flow system (nHF) on tidal volume, breathing rate and minute volume in healthy volunteers and patients with ILD

*Department of Respiratory Medicine, University of Leipzig, Germany
Bräunlich, J; Köhler, M; Hammerschmidt, S; Seyfarth, H-J; Wirtz, H*

THERAPY WITH NASAL INSUFFLATION INCREASES RESPIRATORY EFFICIENCY IN COPD PATIENTS

2012

Publikation 2012 August in PubMed I Adv Exp Med Biol. 2013;755:27-34.
Effects of Nasal Insufflation on Arterial Gas Exchange and Breathing Pattern in Patients with Chronic Obstructive Pulmonary Disease and Hypercapnic Respiratory Failure.

Nilius G, Franke KJ, Domanski U, Rühle KH, Kirkness JP, Schneider H.
Source HELIOS Klinik Hagen-Ambrock, Klinik für Pneumologie, Universität Witten-Herdecke, Ambrocker Weg 60, 58091, Hagen, Germany

2013

Respiration

Clinical Investigations

Respiration 2013;85:319-325
DOI: 10.1159/000342027

Effects of Nasal High Flow on Ventilation in Volunteers, COPD and Idiopathic Pulmonary Fibrosis Patients

Jens Bräunlich Denise Beyer David Mai Stefan Hammerschmidt
Hans-Jürgen Seyfarth Hubert Wirtz

Department of Respiratory Medicine, University of Leipzig, Leipzig, Germany

2013

nHF AN ACCEPTABLE TREATMENT OPTION

Nasal High Flow Oxygen Therapy attenuates nocturnal hypoventilation in COPD patients with hypercapnic respiratory failure.

G. Nilius¹, U. Domanski¹, K.J. Franke¹, K.H. Rühle¹, H. Schneider²
1 HELIOS Klinik Hagen Ambrock, Universität Witten/Herdecke;
2 John-Hopkins-University Baltimore

CONCLUSION:

Our data implicate that HFO₂ is a readily acceptable treatment option that can improve nocturnal hypoventilation in patients with chronic respiratory failure.



2013

NO SIGNIFICANT DIFFERENCES BETWEEN NIV AND nHF

Long time effects of nasal High Flow (nHF) in patients with COPD

*Department of Pneumology, University of Leipzig
Bräunlich, J.; Seyfarth, H.-J.; Hammerschmidt, S.; Wirtz, H.*

RESULTS:

After 6 weeks we found a significant decrease in paCO_2 (nHF 44,8 mmHg/ BiPAP 46,4 mmHg) in both groups. There were no significant differences.

The nHF device was better tolerated (10 NHF/ 5 BiPAP).

2013

FASTER PACO_2 DECREASE WITH HIGHER FLOWRATES

Nasal High Flow (nHF): Is it a wash – out effect?

*Bräunlich, J.; Köhler, M.; Hammerschmidt, S.; Seyfarth, H.-J.; Wirtz, H.
Department of Pneumology, University of Leipzig*

RESULTS:

We found significant distinctions in mean airway pressure and paCO_2 between 20 l/min and 30 l/min. The volumes and breathing rate showed no differences. The minute volume decreased in comparison to spontaneous breathing.

GENERAL STATEMENTS ON OBSTRUCTIVE SLEEP APNEA (OSA) ACCORDING TO THE NEWEST STUDIES ON TNI

TNI® medical AG has conducted research in the field of sleep as well as OSA.

TNI is recommendable as a form of therapy for children and adults suffering from this disease due to existing results and practice experience.

This includes the successful treatment of children who tend to suffer from OSA due to midface hypoplasia or Down syndrome.

CPAP, however, is the GOLD standard in OSA therapy.

STATEMENTS ON CHILDREN AND ADOLESCENTS WITH OSA

2009

PEDIATRICS

OFFICIAL JOURNAL OF THE AMERICAN ACADEMY OF PEDIATRICS

Pediatric - Effect of a High-Flow Open Nasal Cannula System on Obstructive Sleep Apnea in Children

Pediatrics - official Journal of the American Academy of Pediatrics
Brian McGinley, Ann Halbower, Alan R. Schwartz, Philip L. Smith, Susheel P. Patil and Hartmut Schneider

STATEMENTS ON ADULTS WITH OSA

2010

CHEST

Official publication of the American College of Chest Physicians

Multicenter study to evaluate the efficacy of transnasal insufflation (TNI) in patients with slight to moderate pharyngeal obstruction and sleep apnea.

Klinik Ambrock, Pulmonology, Hagen, Ruhrlandklinik, Pulmonology Essen, University, ENT, Mannheim, Somnolab, Dortmund, University, Pulmonary and critical care, Baltimore
Nilios G.; Wessendorf, T. E.; Frey, S.; Knaack, L.; Wende, W.; Schneider, H.



HOW IS nHF EVALUATED IN CLINICAL APPLICATION TODAY?

Several studies have shown that nHF

- produces a small positive airway pressure.
- improves oxygenation.
- increases end-inspiratory pulmonary volume.
- reduces airway resistance.
- increases functional residual capacity.
- washes out the nasopharyngeal dead space.
- decreases the respiratory rate.
- has a more comfortable application for patients.
- restores pulmonary defense mechanisms.

The most significant physiological effects of nHF are as follows:

1. washing out of dead space in the pharynx.
2. reduction of nasopharyngeal resistance.
3. positive end-expiratory pressure (PEEP effect).
4. alveolar expansion.
5. humidification, high comfort, better tolerance and mucociliary clearance.
6. better control over FiO_2 .

Further recommendations concerning easier and better patient treatment

7. post-extubation phase
8. pre-intubation
9. emergency room
10. bronchoscopy
11. palliative care
12. cardiac insufficiency
13. chronic airway disease

1994 Dewan und Bell
8. Dewan NA, Bell CW. Effect of low flow and high flow oxygen delivery on exercise tolerance and sensation of dyspnea. A study comparing the transtracheal catheter and nasal prongs. *Chest*. 1994;105:1061---5.

1990 Shepard und Burger
Shepard JW, Burger CD. Nasal and oral flow-volume loops in normal subjects and patients with obstructive sleep apnea. *Am Rev Respir Dis*. 1990;142:1288---93.

2007 Groves
5. Groves N, Tobin A. High flow nasal oxygen generates positive airway pressure in adult volunteers. *Aust Crit Care*. 2007;20:126---31.

2009 Parke
6. Parke R, McGuinness S, Eccleston M. Nasal high-flow therapy delivers low level positive airway pressure. *Br J Anaesth*. 2009;103:886---90.

2011 Corley
13. Corley A, Caruana LR, Barnett AG, Tronstad O, Fraser JF. Oxygen delivery through high-flow nasal cannulae increase end-expiratory lung volume and reduce respiratory rate in postcardiac surgical patients. *Br J Anaesth*. 2011;107:998---1004.

2009 Chaques
15. Chanques G, Constantin JM, Sauter M, Jung B, Sebbane M, Verzilli D, et al. Discomfort associated with under humidified high-flow oxygen therapy in critically ill patients. *Intensive Care Med*. 2009;35:996---1003.

2011 Sztrymf
12. Sztrymf B, Messika J, Mayot T, Lenglet H, Dreyfuss D, Ricard JD. Impact of high-flow nasal cannula oxygen therapy on intensive care unit patients with acute respiratory failure: a prospective observational study. *J Crit Care*. 2012;27:324.e9---13.

2013 Zusammenfassung Gotera
Clinical evidence on high flow oxygen therapy and active humidification in adults
C. Goteraa, S. Diaz Lobatoa, T. Pintob, J.C. Winckb
a Pneumological Department, Ramón y Cajal Teaching Hospital, Madrid, Spain
b Centro Hospitalar São João, Faculdade de Medicina, Universidade do Porto, Porto, Portugal

THE MOST SIGNIFICANT PHYSIOLOGICAL EFFECTS ARE AS FOLLOWS:

1. Washing out of Dead Space in Pharynx

One of the main effects is the washing out of CO₂ in the nasopharynx and reducing re-breathed CO₂. This corresponds to a reduction of the functional dead space and increases alveolar ventilation.

These characteristics have clinical benefits regarding exercise tolerance, dyspnea regression and better oxygen supply.

In **1994**, Dewan and Bell examined the clinical effects of high-flow oxygen in exercise tolerance and the feeling of dyspnea.

The most important result of the study was that high-flow oxygen improves exercise results in COPD patients who are heavily addicted oxygen!

2. Reduction of Nasopharyngeal Resistance

In **1990**, Shepard and Burger discovered that the nasopharyngeal space has an extensibility which contributes to a variable resistance. When inspiratory gas flows over this large surface, the nasopharyngeal walls contract causing a significant increase in inspiratory resistance in contrast to expiratory resistance. nHF most likely reduces inspiratory resistance in the nasopharynx through nasopharyngeal gas flow supply which meets or succeeds the patient's peak inspiratory flow (PIF).

3. Positive expiratory pressure (PEEP effect)

In **2007**, Groves and Tobin documented the following in healthy people: their test subjects were fitted with nasal prongs and their pharyngeal pressure was recorded in flow-rates of 0 to 60 L/min.

A flow-dependent generation of positive expiratory pressure was measured in which mean pressures of 7.4 cm H₂O at 60 L/min with a closed mouth were obtained.

These findings were confirmed by Parke et al. in **2009**. The researchers studied the connection between flow and pressure in nHF therapy.

15 patients were asked to participate in the study on nHF; measurements with a flow of 30, 40 and 50 L/min were conducted with the patients' mouths closed and open.

In conclusion, nHF was not suggested as an alternative therapy to CPAP or NIV but it could bridge the gap to these therapies.

4. Alveolar Expansion (Recruitment)

In a 2011 study conducted by Corley et al. with 20 patients, it was discovered that nHF can correct hypoxemia by use of certain mechanisms when applied via nasal prongs and thus contributes to alleviating dyspnea. The positive airway pressure effect gives a certain dimension to pulmonary extensibility pressure and alveolar expansion but it is unclear how its application affects pulmonary volume; the aim of this research was to examine the effects of nHF on airway pressure and expiratory pulmonary volume.



The authors discovered a significant correlation between the end-expiratory pulmonary impedance and airway pressure. They also discovered that the results were quite favorable for patients with larger body mass indices.

The results of this study are important in that it shows that an improvement in oxygenation can be traced back to alveolar expansion in patients with severe respiratory failure.

5. Humidification, High Comfort, Better Tolerance

In a study conducted in **2009** with 30 patients who were being treated with nHF, Chanques et al. showed the application of heated air humidifiers on patients being treated with nHF with a decrease in dryness symptoms which were prevented by increased humidity. Effective humidity management can indirectly affect oxygenation in a positive way.

Active humidification

- improves mucociliary clearance.
- facilitates secrete reduction.
- reduces formation of atelectases
- which improves ventilation-perfusion ratio
- and oxygenation.

In **2011**, Sztrymf et al. showed in a study focused on the effects of nHF therapy in patients in intensive care with severe respiratory failure that none of the patients dropped out of the therapy due to complaints.

By providing ideal humidification, patients are able to maintain the functionality of the mucociliary transport system, secretes can be coughed up more easily and the risk of the airways becoming infected is reduced. This can be especially beneficial for COPD patients suffering from secretion problems.

The positive effects stand in direct correlation with active humidification.

6. Better Control Over FiO₂ and Better Mucociliary Clearance

Moreover, the proposed mechanisms could possibly help control the patient's FiO₂ better.

WHY CHOOSE TNI SOFTFLOW

Therapie with **IN**asal **||**nsufflation

“ For TNI® medical AG, the game has always been in the name. ”

This form of therapy is commonly known as High Flow, HF, nasal High Flow, nHF or similar terms. It has been in practice for several years but still no clear standardizations exist.

TNI® medical AG recognized this negligence and undertook measures against this from the foundation of the company by specifying clear and precise parameter guidelines.

Specialized literature has been pointing to the good and attested therapeutic results of nHF for the past three years. These published studies mainly present and interpret results which have been distributed unsystematically and sporadically since the 1990s. The sample size in the individual studies is small.

Additionally, nasal high-flow therapy was always conducted in a clinical environment; no system was available for medical professionals for home care environments until 2008. This gap has been bridged by the TNI®20 and TNI®20 oxy systems.

Why could this therapy be practiced in clinical environments?

Every clinic is provided with compressed air and oxygen from wall connections, with pressures of approximately 5 bars; flowrates are decreased either manually or electronically by blenders. This enables an almost entirely constant flow combined with a humidification system from NIV, making the therapy tolerable.

The quality standards of the humidification systems used by patients and professionals lack standardization for high flowrates.

From the beginning, TNI® medical AG has made a point of providing research-based evidence for all positive and negative effects that can occur during therapy.



Therapy with nasal insufflation means:

The exact, regulated flowrate (in l/min) of air or air-O₂ mixture is the therapy parameter!

Tolerance of ± 0.1 L/min.

Tolerance of ± 2 %

A steady FiO₂ is guaranteed and displayed at any point of the therapy!

A constant FiO₂ is absolutely necessary for safe therapy.

The applied amount of O₂ is shown in the display in L/min.

The FiO₂ value resulting from the flowrate is shown in the display.

Balanced and individually customizable humidification management is guaranteed for high and low flowrates!

The cyclone-like humidification system guarantees individually customizable and exact humidity management for high and low flowrates.

Well-temperated applicator heaters up to nasal prongs

The “heater to the tip of your nose” is a standard application, together with a soft, flexible and thin air supply tube. The nasal prongs are comfortable to wear and do not condense.

Well-thought through hygiene system

Cleaning and sterilizing the device is simple and easy to do.

Through the usage of standard MRE filters, a cross contamination between system and patient is precluded.

All pieces of the system which are contaminated by the patient can be single-use products.

Easy and fast patient system changes guaranteed.

Professional application in clinical and home care settings

In the clinic

Auto fill humidifier chamber
MRE filter

At home

600 ml water tank
Tap or demineralized water
Auto fill humidifier chamber (optional)

LTOT during power outages

Power outages occur even in the Western world. Should the system shut down during a power outage, the patient will still be provided with oxygen during the outage. The patient's oxygen supply is always guaranteed at the set amount of oxygen from a wall connection and fluid gas supply.

Integrated in one housing

Everything is integrated into one housing.

Your TNI Team







*If new medical insights are
shown in precise technology,
technology is boosting medical progress*

Your partner in breathing support



TNI medical AG • Hofmannstraße 8 • D 97084 Wuerzburg
phone +49 931 20 79 29 02 • fax +49 931 20 79 29 18
www.tni-medical.de • info@tni-medical.de